

WX5025 Datasheet

2024.8

申明

位

位

位

REVISION HISTORY 3

) OP (..... 1

))

)))

))



))

- H 0()I !
- =LK 0()IYr!
- I F 0()IY !
- N=H9
- =L9
- EA: EGF
- NPD9F]f]] FN =

)) +

- AH L H K
- G=
- L H C:
- Dafck][
- AHK][
- AH L H M<H KL H
- 了 M<H
-
- ND9F LY_
- 优 E9 ND9F
-

))

- EKA EKA%P
- 了
- L H
- LH D A<G 9 A NH< = 9= N<E
-) :)C:
- H A=
- << <+ 9 HA

))

- K %AGN
-) 0 优
- +
-

-) 0
- DDA
-
- +
-) 0 E9
- (1 了
- (1 了
-

))

-
- H A]]f p) p p p0
- D9F 0 HAG
- D9F) AA
- KHA
- M9 L
- F KA
- 0 HAG
- KE k
-

)

			但

	了

	(1) () (N
	(1) () (N
	(0	(1	(1	N
	((0	(0	N
)) 0) 10	N
	(0	(1	(1	N
)) 0) 10	N

) +

	Min	Typ	Max	Units	Ripple
	((z	
))) 0) 01	N	(eN
))) 0) 01	N	(eN
))) 0) 01	N	(eN
))) 0) 01	N	(eN

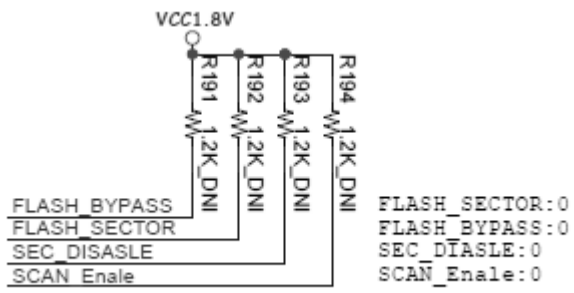
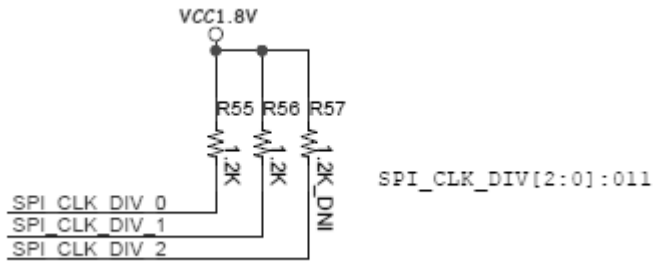

串

) + =L

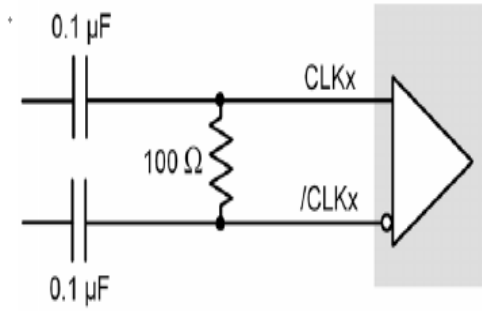

) +

OP (H A= (1N) ON (ON (1N) (N) ON) (N) ON D<G
 =L =L (WN<<9W AGW E =L)WN<<9W AGW E H Q
 =L =L)WN<<9W G =W E P =L)WN<<9W G =W E P H Q
 =L =L (WN<<<W G =W9F9W P =L)WN<<<W G =W9F9W P H Q
 串 H Q H=WH QWNH (1N
 个 H=WH QWNH TN<<9)0) ON 个
 : DE)OH +((KF)) (f T) ((f T T) ((1N
) 9 (1N 9) (0
) ON) (N 9 D<G

) +

	Min	Typ	Max	Units
LHMW =K=L =K=L !) (ek
L =K=L) (ek

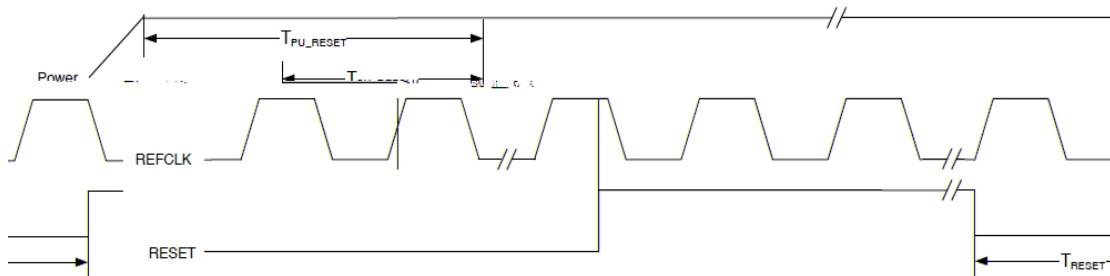

) + 0 F KA 9 Kh][a a[Y agf

Symbol	Parameter	Min	Typ	Max	Units
L[c	F KAW = W DC j]i]f[q		(E r
\[F KAW = W DC \ q [q[d]	+			
Y[[F KAW = W DC Y[[jY[q))((hhe
L[g	dg[c% g%g)(h [dgY\ (h ! F KAW P<S) (U F KAW K W<N <Y Y Yda\ jge F KAW = W DC jakaf_]\[_]	+			fk
Lk	F KAWLP<S) (U F KAWLPW=F <Y Y K] h g F KAW DCWAF jakaf_]\[_]	+			fk
L gd\ L	F KAWLP<S) (U F KAWLPW=F <Y Y gd\ jge F KAW = W DC jakaf_]\[_])			fk
Lgj	F KAW P<S) (U F KAW K W<N G h Lae] jak]	(fk
Lg	F KAW P<S) (U F KAW K W<N G h Lae] Ydd	(fk
L[cj L[c	F KAW = W DC ak] Ydd Lae]	(+	fk

) + 1 D9K

Manufacturer	Model type
c N	2
T	2
SM Qb Q	0

KHA D9K

) +)(

Manufacturer	Part Number	Model type
R		

) +)) H AW=phj]kk

- H AW=phj]kk + hk
- ↑ (
- +ead
- +0
- LP P
- H A= (=E
- H A= LP P 0 g e)((g e)(
- H A= =E (K][agf)) 9\\%af Yj\ DYqg]i aj]e]f k Yf\]][gee]f\Y agfk

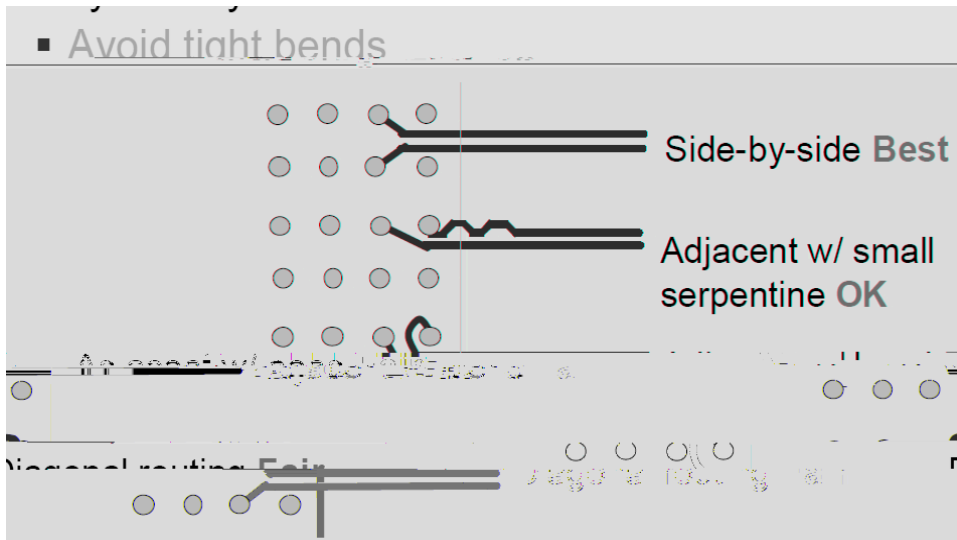

) +) K H

- K H K HW P K HWLP ead (ead)(LP P

- K A LP P k

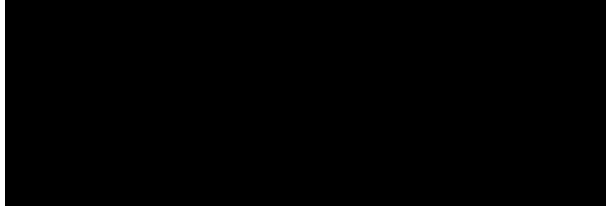

- K H N + +N)9
- K H
- K A LP P

